

ITEM	DESCRIPTION	MATERIAL	QTY
1	GROOVED END PIPE (AWWA C606 STANDARD)	METALLIC/NON METALLIC	2
2	COUPLING HOUSING	CE8MN/CE3MN (DUPLEX/SUPERDUPLEX STAINLESS STEEL)	2
3	GASKET	EPDM RUBBER	1
4	ROUND/HEX HEAD, SQUARE/ OVAL NECK BOLT	316 STAINLESS STEEL / DUPLEX 2205	2
5	WASHER	316 STAINLESS STEEL / DUPLEX 2205	2/4
6	HEAVY HEX NUT	316 STAINLESS STEEL / DUPLEX 2205	2

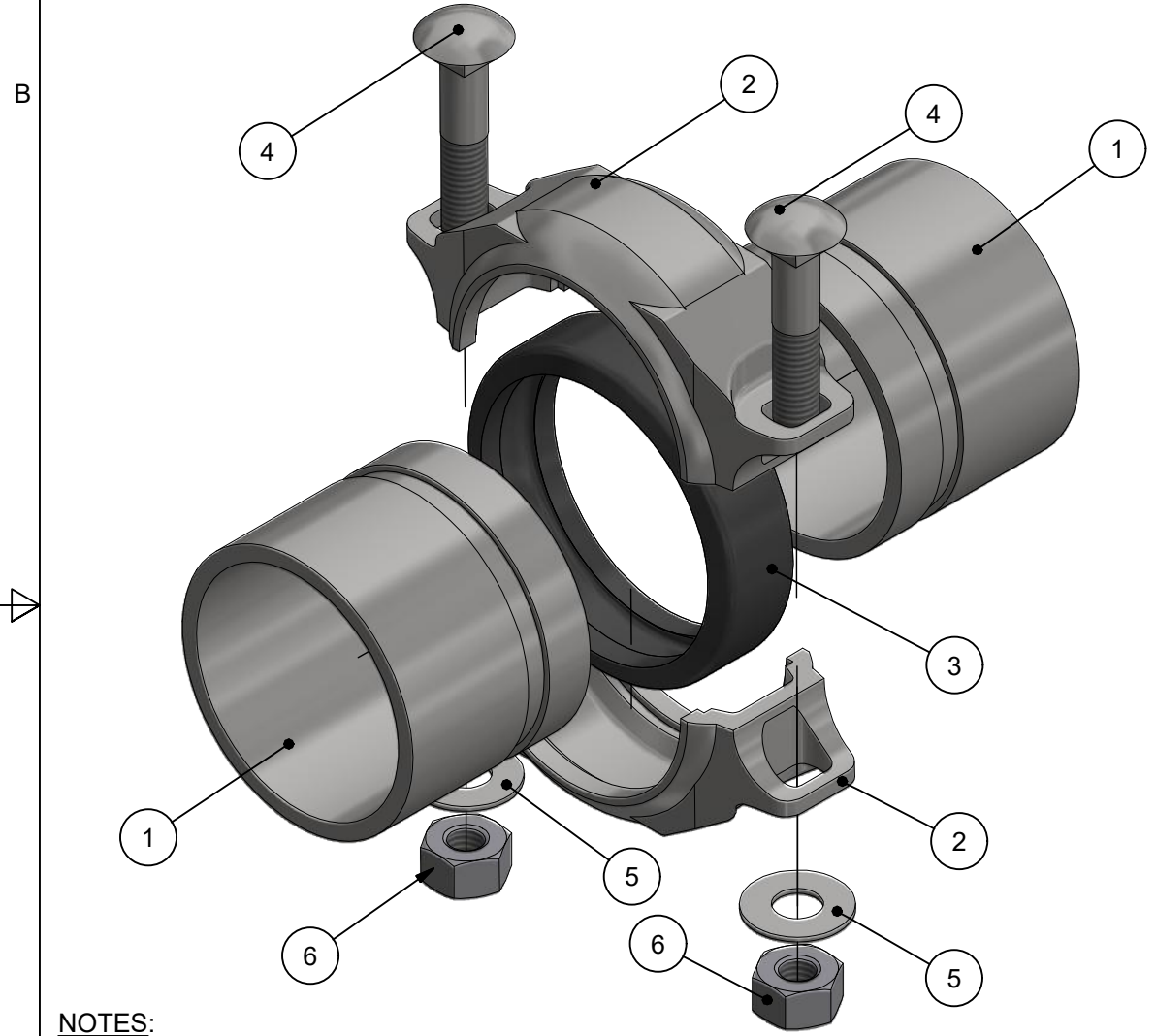
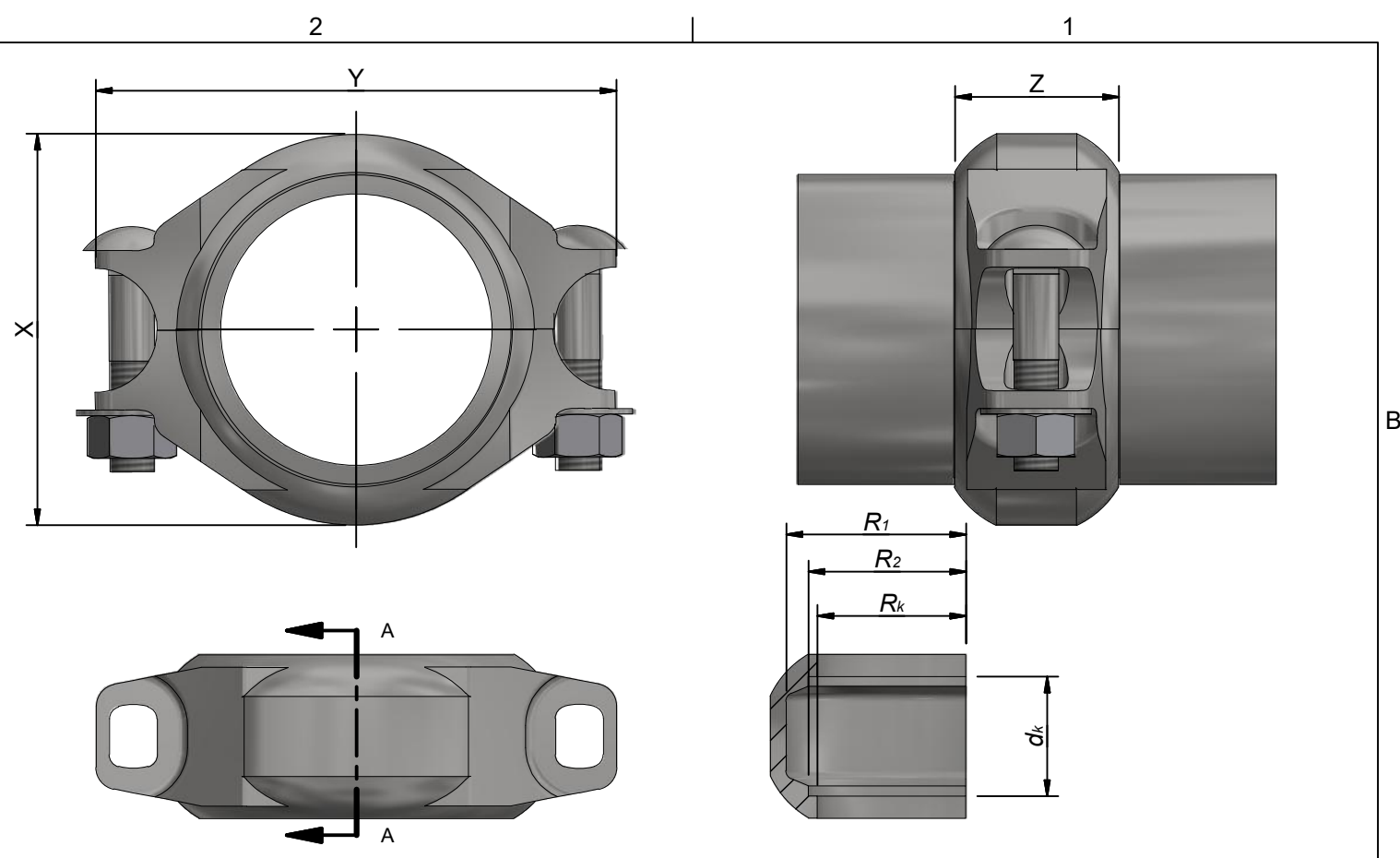

PRESSURE RATING:

NOMINAL SIZES	RATED PRESSURE	PROOF TEST PRESSURE
0.75" - 8"	1200 PSI (83 BAR)	1800 PSI (125 BAR)
10" - 14"	1200 PSI (83 BAR)	1800 PSI (125 BAR)

DIMENSIONS:

NOMINAL SIZE	X	Y	Z	dk	R1	R2	Rk	APPROX. WT
INCH	INCH [MM]	INCH [MM]	INCH [MM]	INCH [MM]	INCH [MM]	INCH [MM]	INCH [MM]	LB [KG]
3/4	1.91 [48.5]	3.04 [77.2]	1.68 [42.7]	1.37 [34.8]	0.81 [20.5]	0.54 [13.6]	0.48 [12.1]	0.81 [0.37]
1	2.29 [58.2]	3.42 [86.9]	1.68 [42.7]	1.37 [34.8]	1.00 [25.4]	0.67 [16.9]	0.60 [15.2]	0.97 [0.44]
1-1/4	2.50 [63.5]	3.65 [92.7]	1.71 [43.4]	1.35 [34.3]	1.11 [28.2]	0.85 [21.6]	0.77 [19.6]	1.08 [0.49]
1-1/2	2.76 [70.1]	4.06 [103.1]	1.71 [43.4]	1.35 [34.3]	1.23 [31.2]	0.98 [24.9]	0.90 [22.7]	1.21 [0.55]
2	3.24 [82.3]	4.38 [111.3]	1.85 [47.0]	1.35 [34.3]	1.47 [37.3]	1.21 [30.7]	1.13 [28.7]	1.92 [0.87]
2-1/2	3.74 [95.0]	5.30 [134.6]	1.85 [47.0]	1.35 [34.3]	1.72 [43.7]	1.46 [37.0]	1.37 [34.7]	2.14 [0.97]
3	4.48 [113.8]	6.08 [154.4]	1.85 [47.0]	1.35 [34.3]	2.03 [51.6]	1.78 [45.2]	1.68 [42.7]	2.64 [1.20]
4	5.70 [144.8]	7.60 [193.0]	2.02 [51.3]	1.50 [38.1]	2.64 [67.1]	2.28 [57.9]	2.17 [55.2]	4.54 [2.06]
5	7.22 [183.4]	9.50 [241.3]	2.02 [51.3]	1.50 [38.1]	3.18 [80.8]	2.82 [71.5]	2.70 [68.7]	9.30 [4.23]
6	8.18 [207.8]	10.25 [260.4]	2.02 [51.3]	1.50 [38.1]	3.71 [94.2]	3.34 [84.8]	3.23 [82.1]	9.74 [4.42]
8	10.89 [276.6]	13.44 [341.5]	2.34 [60.7]	1.75 [44.5]	4.78 [121.4]	4.35 [110.4]	4.23 [107.3]	24.50 [11.10]
10	13.28 [337.3]	15.88 [403.2]	2.55 [64.8]	1.75 [44.5]	5.85 [148.5]	5.41 [137.5]	5.29 [134.3]	33.46 [15.18]
12	15.28 [388.1]	17.38 [441.4]	2.55 [64.8]	1.75 [44.5]	6.85 [173.9]	6.41 [162.9]	6.27 [159.3]	34.82 [15.80]
14	16.45 [417.7]	20.30 [515.7]	2.99 [75.8]	2.13 [54.0]	7.47 [189.8]	7.04 [178.7]	6.90 [175.2]	44.91 [20.38]

NOTES:

- DIMENSIONS SHOWN IN THE DRAWING ARE INDICATIVE. FOR DETAILED INFORMATION ON GD&T, CONTACT PIEDMONT
- COUPLING IS RATED FOR SCH. 40 PIPE (OR THICKER) WITH CUT GROOVES ONLY
- HOUSING MATERIAL IS DUPLEX (CE8MN) OR SUPER DUPLEX (CE8MN/CE3MN) STAINLESS STEEL, CONFORM TO ASTM A995/A995M-13
- BOLTS ARE ROUND/ HEX HEAD, SQUARE / OVAL NECK, 316SS / DUPLEX 2205 BOLTS
- NUTS ARE HEAVY HEX 316SS / DUPLEX, CONFORM TO DIN 934.
- WASHERS ARE 316SS / DUPLEX, CONFORM TO DIN 125.
- GASKETS ARE EPDM RUBBER (FLUSH-FIT/C-SHAPE)

PROPRIETARY AND CONFIDENTIAL NOTE:
THE INFORMATION CONTAINED IN THIS DRAWING IS THE SOLE PROPERTY OF PIEDMONT PACIFIC. ANY REPRODUCTION IN PART OR AS A WHOLE WITHOUT THE WRITTEN PERMISSION OF PIEDMONT PACIFIC IS PROHIBITED.

REV	DATE	REVISION DESCRIPTION	DRAWN	CHKD	ENG	APPVD
4	23-03-2016	D3.0 DIMENSION WAS REVISED	AH	CZZ	AH	AH
5	18-07-2016	PRODUCT WEIGHTS ARE ADDED. DIMENSIONS REVISED.	AH	CZZ	AH	AH
6	08-09-2017	TABLE UPDATED	JF	CZZ		
7	02-11-2017	TABLE UPDATED	JF	CZZ		
8	09-08-2018	TABLE UPDATED	JF	CZZ		

UNLESS NOTED OTHERWISE
INTERPRETATION: ANSI Y14.5
TOLERANCES: 40.00° (0.75 MM)
ANGLES: 4° 1'
HOLE SIZES: 40.00° (0.75 MM)
HOLE CENTERS: 40.00° (0.75 MM)
SURFACE FINISH ON PART: 125
SURFACE FINISH ON CHANGES: 125
DO NOT SCALE PRINTS

PIEDMONT PACIFIC
GROOVE END FLEXIBLE PIPE COUPLING

TITLE:				
STYLE D COUPLING ASSEMBLY				
SCALE:	UNIT:	DRAWING NO.	SHEET:	REVISION:
N/A	INCH [MM]	1.0	1.0	8