

VIEW AT CENTER SUPPORT
 CENTER VESSEL ON 2 OR 3 SUPPORTS
 AT SPAN(S) "S": 3 SUPPORTS REQUIRED
 FOR LENGTHS -4 AND OVER

DWG REF	QTY	PART NUMBER	DESCRIPTION	MATERIAL
SHELL				
1	1	99280	SHELL	Filament Wound Epoxy/Glass composites - Head locking grooves integrally wound in place.
2	A/R	REF. PAGE 2	F/C Port	SA-351 CF3M
3	A/R	47135	F/C Port Seal	Ethylene Propylene - Square Cut
4	A/R	45251	F/C Port Retainer	18-8 Stainless Steel
HEAD				
5	2	96827	End Plug	Engineering Thermoplastic.
6	2	45317	Head Seal	Ethylene Propylene - O - Ring
HEAD INTERLOCK				
7	2	45260	Retainer Ring	SA-479 SS316
VESSEL SUPPORT				
8	2*	45058	Saddle	Engineering Thermoplastic.
9	2*	47459	Strap Assy.	304 Stainless Steel-PVC Cushion.
10	4**	97821	Strap Screw	5/16-18 UNC X 1.5" L, 18-8 Stainless Steel
ELEMENT INTERFACE				
11	2	A/R	Adapter	Engineering Thermoplastic.
12	2	45296	Adapter seal	Ethylene Propylene - O - Ring
13	A/R	A/R	PWT seal	Ethylene Propylene - O - Ring

*3 each & **6 nos. furnished with length code 4,5 & 6.

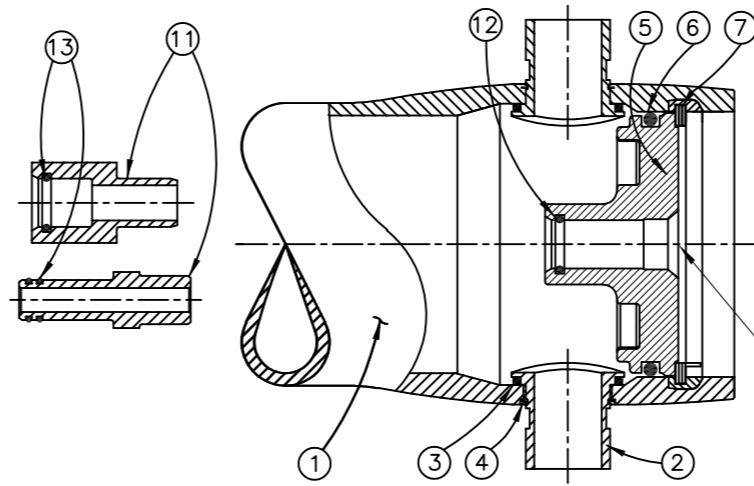

CAUTION: INCORRECT MANIFOLDING WILL CAUSE SEVERE LOCAL STRESS AROUND PORT AND MAY RESULT IN LEAKS AND PREMATURE FAILURE; TAKE EVERY PRECAUTION LISTED ON PAGE 02, SEE INSTALLATION INSTRUCTIONS FOR FURTHER DETAILS

Dash Length	PORT LOCATION			Approx Weight LB(KG)
	L IN(MM)	P IN(MM)	S IN(MM)	
-1	48.50 (1232)	42 (1067)	25X1 (635)	21 (10)
-2	88.50 (2248)	82 (2083)	56X1 (1422)	31 (14)
-3	128.50 (3264)	122 (3099)	80X1 (2032)	41 (19)
-4	168.50 (4280)	162 (4115)	64X2 (1626)	51 (23)
-5	208.50 (5296)	202 (5131)	78X2 (1981)	61 (28)
-6	248.50 (6312)	242 (6147)	92X2 (2337)	72 (33)

GENERAL NOTES:
 1. DIMENSIONS IN INCHES (MM APPROX).
 2. NOT TO BE USED FOR CONSTRUCTION UNLESS CERTIFIED.
 3. SHELL EXTERIOR COATED WITH WHITE RAL 9003, HIGH GLOSS POLYURETHANE PAINT.

THIS DOCUMENT AND THE INFORMATION CONTAINED HEREIN, ARE THE CONFIDENTIAL AND PROPRIETARY INFORMATION OF PENTAIR INDIA PVT. LTD. PENTAIR INDIA PVT. LTD. IS THE SOLE OWNER OF THE INFORMATION AND PROCESSES DEFINED HEREIN. THIS DOCUMENT, AND THE INFORMATION CONTAINED, MAY NOT BE DISCLOSED, REPRODUCED, DUPLICATED, USED, SOLD, PUBLISHED, COMMUNICATED OR OTHERWISE DISTRIBUTED, IN WHOLE OR IN PART, FOR ANY PURPOSE WITHOUT THE EXPRESS WRITTEN CONSENT OF PENTAIR INDIA PVT. LTD. THIS DOCUMENT AND ANY COPIES, IN ALL APPLICABLE FORMATS, SHALL BE RETURNED TO PENTAIR INDIA PVT. LTD. UPON REQUEST.

ALL INDICATED PENTAIR TRADEMARKS AND LOGOS ARE PROPERTY OF PENTAIR. THIRD PARTY REGISTERED AND UNREGISTERED TRADEMARKS AND LOGOS ARE PROPERTY OF THEIR RESPECTIVE OWNERS. BECAUSE WE ARE CONTINUOUSLY IMPROVING OUR PRODUCTS AND SERVICES, PENTAIR RESERVES THE RIGHT TO CHANGE SPECIFICATIONS WITHOUT PRIOR NOTICE. PENTAIR IS AN EQUAL OPPORTUNITY EMPLOYER.

© 2021 Pentair. All Rights Reserved.

PENTAIR VERNA, GOA INDIA
CODELINE

DRAWN BY: RA	DRAWING DESCRIPTION: MODEL-40S60 NC MEMBRANE HOUSING	DRAWING NO.: 99314	REV.: R
CHECKED BY: KPS	CUSTOMER NAME: -	VESSEL MODEL: 40S60 (NC)	
DATE: 15/09/21	PROJECT NAME: -	TOTAL QTY: -	
APPROVED BY: FF	CUSTOMER P.O.#: -	SIZE: A3	SCALE: NONE
DATE: 15/09/21	DATE: 16/12/21	PAGE NO.: 01 OF 02	

RATING:

DESIGN PRESSURE.....	600 PSI (4.14 Mpa)
MAX. OPERATING TEMP.....	120°F (49°C)
MIN. OPERATING TEMP.....	20°F (-7°C)
FACTORY TEST PRESSURE.....	900 PSIG (6.21 MPa)
BURST PRESSURE.....	3600 PSI (24.82 MPa)

INTENDED USE:

The Model 40S60 Fiberglass RO/UF Pressure Vessel is designed for continuous, long term use as housing for reverse osmosis and ultrafiltration elements in typical industrial water treatment systems at pressures up to 600 psi. Any make of four-inch nominal diameter spiral-wound element is easily accommodated. The appropriate interfacing hardware for the element specified is furnished with the vessel.

The Model 40S60 is designed in accordance with the engineering standards of the Boiler and Pressure Vessel Code of the American Society of Mechanical Engineers (ASME Code) Section X Edition 2021 and all metallic parts are designed as per Section VIII Division I Edition 2021.

The Model 40S60 must be installed, operated and maintained in accordance with the listed precautions and good industrial practice to assure safe operation over a long service life.

The high performance reinforced plastic shell must be allowed to expand under pressure; undue restraint at support points or piping connections can cause leaks to develop in the shell. This side ported vessel requires special precautions in mounting and connection to piping so that the vessel will not be subjected to excessive stress due to bending moments acting at the side openings in the fiberglass shell.

The end closures, incorporating close-fitting, interlocking metal components, must be kept dry and free of corrosion; deterioration can lead to catastrophic mechanical failure of the heads.

Pentair will assist the purchaser in determining the suitability of this standard vessel for their specific operating conditions. The final determination however, including evaluation of the standard material of construction for compatibility with the specific corrosive environment, shall be the responsibility of the purchaser. Alternate materials with enhanced corrosion resistance are available on special order.

Specifications are subject to change without notice.

PRECAUTIONS:

- DO...read, understand and follow all instructions; failure to take every precaution will void warranty and may result in vessel failure
- DO...mount the shell on horizontal members at span "S" using complaint vessel supports furnished; tighten hold down straps just snug
- DO...align and center side ports with the manifold header. Correct, causes of misalignment in a row of vessels connected to the same header
- DO...use flexible type IPS grooved-end pipe couplings, at side ports; allow full, 0.125 inch gap between port and piping, and position piping to maximize flexibility of connection
- DO...provide flexibility in, and support for piping manifolds so that vessel can grow in length under pressure without undue restraint; provide additional flexible joints in large pipes leading to manifold header
- DO...provide overpressure protection for vessel set at not more than 105% of design pressure
- DO...inspect end closures regularly; replace components that have deteriorated and correct causes of corrosion
- DO NOT...work on any component until first verifying that pressure is relieved from vessel
- DO NOT... make rigid piping connections to ports or clamp vessel in any way that restricts growth of fiberglass shell under pressure; ΔDIA = 0.01 in. (0.25mm) and ΔL = 0.140 in. (3.5mm) for a length code -6 vessel
- DO NOT... hang piping manifolds from ports or use vessel in any way to support other components.
- DO NOT... operate vessel at pressures and temperatures in excess of its rating
- DO NOT... operate vessel without permeate ports internally connected with a complete set of elements and interconnecting hardware.
- DO NOT... operate vessel with permeate pressure in excess of 125 psi at 120°F (0.86 MPa @ 49°C)
- DO NOT... overtighten the connection to the permeate port (hand-tighten plus one-quarter turn, check for leaks)
- DO NOT... tolerate leaks or allow end closures to be routinely wetted in any way
- DO NOT... pressurize vessel until double-checking to verify that the retaining ring is completely inside the groove
- DO NOT... operate outside the pH range 3-11

CAUTION:
EYE PROTECTION SHOULD BE WORN WHEN REMOVING OR INSTALLING RETAINING RING. KEEP FINGERS CLEAR FROM RETAINING RING WHILE INSTALLING LAST OF TWO TURNS. RING MAY SNAP INTO POSITION POSSIBLY PINCHING FINGERS

ORDERING:

Using the chart below, please check the features you require and fax them with your purchase order to our customer service department for expedited processing. For optional materials and/or features not listed below, please consult factory for pricing and availability.

Please note that we require your membrane brand and model number when ordering. If this information is not initially available, you may provide it at a later date by checking the appropriate box below.

VESSEL LENGTH CODE – please check one

CODELINE MODEL 40S60 Non Coded -1 -2 -3 -4 -5 -6

MEMBRANE BRAND AND MODEL – please check one and fill in information

- Please supply adapters for the following membrane brand and specific model
Brand _____ Model _____
- Membrane brand and model information is not available, but will be supplied to Pentair on or before the following date ____/____/____

CERTIFICATION – please check required

- CE Marked.
- Standard, Certified by Pentair, not code stamped.

EXTERIOR FINISH

- Standard – White high-gloss RAL 9003 polyurethane coating over sanded surface.

FEED PORT CONFIGURATION

- Standard – 1” IPS Grooved End
- Optional – Multi-Ports, Port clocking.

Serial number	Opposite
End	End
<input type="checkbox"/>	<input type="checkbox"/>
<input type="checkbox"/>	<input type="checkbox"/>

PERMEATE PORT CONFIGURATION

- Standard – ½” NPT Female (Standard per drawing)
- Optional - ½” BSPT/JISPT Female

Please fill out your feed port configuration in the space below. List port location first followed by port size for each choice.

Serial number end	<input type="checkbox"/> <input type="checkbox"/> <input type="checkbox"/> <input type="checkbox"/> <input type="checkbox"/> <input type="checkbox"/> <input type="checkbox"/> <input type="checkbox"/>
Opposite end	<input type="checkbox"/> <input type="checkbox"/> <input type="checkbox"/> <input type="checkbox"/> <input type="checkbox"/> <input type="checkbox"/> <input type="checkbox"/> <input type="checkbox"/>

PORT SIZE CODE	PART NO.
A	¾” NPT FEMALE 97778
B	¾” BSPT/JISPT FEMALE -----
C	1” GROOVED END 96057

For complete information on proper use of the vessel Please refer to 40S series USER'S GUIDE - 96897

NOTE
Spiral Retaining Ring Removal Tool (50303)
Recommended to open and close vessel.

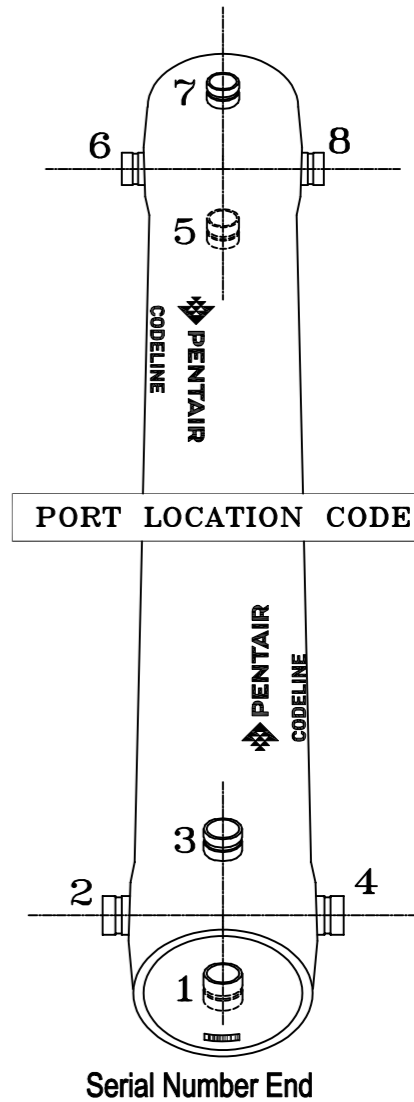

CODELINE BODY LABELS ARE PLACED AT 90° ON SERIAL NUMBER END AND AT 270° ON THE OPPOSITE SIDE END

THIS DOCUMENT AND THE INFORMATION CONTAINED HEREIN, ARE THE CONFIDENTIAL AND PROPRIETARY INFORMATION OF PENTAIR INDIA PVT. LTD. PENTAIR INDIA PVT. LTD. IS THE SOLE OWNER OF THE INFORMATION AND PROCESSES DEFINED HEREIN. THIS DOCUMENT, AND THE INFORMATION CONTAINED, MAY NOT BE DISCLOSED, REPRODUCED, DUPLICATED, USED, SOLD, PUBLISHED, COMMUNICATED OR OTHERWISE DISTRIBUTED, IN WHOLE OR IN PART, FOR ANY PURPOSE WITHOUT THE EXPRESS WRITTEN CONSENT OF PENTAIR INDIA PVT. LTD. THIS DOCUMENT AND ANY COPIES, IN ALL APPLICABLE FORMATS, SHALL BE RETURNED TO PENTAIR INDIA PVT. LTD. UPON REQUEST.

ALL INDICATED PENTAIR TRADEMARKS AND LOGOS ARE PROPERTY OF PENTAIR. THIRD PARTY REGISTERED AND UNREGISTERED TRADEMARKS AND LOGOS ARE PROPERTY OF THEIR RESPECTIVE OWNERS. BECAUSE WE ARE CONTINUOUSLY IMPROVING OUR PRODUCTS AND SERVICES, PENTAIR RESERVES THE RIGHT TO CHANGE SPECIFICATIONS WITHOUT PRIOR NOTICE. PENTAIR IS AN EQUAL OPPORTUNITY EMPLOYER.

©2021 Pentair. All Rights Reserved.



DRAWN BY: RA	DATE: 15/09/21	DRAWING DESCRIPTION: MODEL - 40S60 NC MEMBRANE HOUSING	DRAWING NO.: 99314	REV.: R
CHECKED BY: KPS	DATE: 15/09/21	CUSTOMER NAME: -	VESSEL MODEL: 40S60 (NC)	
APPROVED BY: FF	DATE: 15/09/21	PROJECT NAME: -	TOTAL QTY: -	
ECN NO.: 5881	DATE: 16/12/21	CUSTOMER P.O.#: -	SIZE: A3	SCALE: NONE
				PAGE NO.: 02 OF 02